

PB 282 426



NATIONAL TRANSPORTATION SAFETY BOARD

WASHINGTON, D.C. 20594

RAILROAD ACCIDENT REPORT

SIDE COLLISION OF
SOUTHERN RAILWAY COMPANY
TRAINS NOS. 1 AND 152
SPENCER, NORTH CAROLINA
OCTOBER 8, 1977

REPORT NUMBER: NTSB-RAR-78-3

UNITED STATES GOVERNMENT

REPRODUCED BY
NATIONAL TECHNICAL
INFORMATION SERVICE
U. S. DEPARTMENT OF COMMERCE
SPRINGFIELD, VA. 22161

TECHNICAL REPORT DOCUMENTATION PAGE

1. Report No. NTSB-RAR-78-3		2. Government Accession No.		3. Recipient's Catalog No. 126	
4. Title and Subtitle Railroad Accident Report -- Side Collision of Southern Railway Company Trains Nos. 1 and 152, Spencer, North Carolina, October 8, 1977				5. Report Date May 11, 1978	
				6. Performing Organization Code	
7. Author(s)				8. Performing Organization Report No.	
9. Performing Organization Name and Address National Transportation Safety Board Bureau of Accident Investigation Washington, D.C. 20594				10. Work Unit No. 2228	
				11. Contract or Grant No.	
12. Sponsoring Agency Name and Address NATIONAL TRANSPORTATION SAFETY BOARD Washington, D. C. 20594				13. Type of Report and Period Covered Railroad Accident Report October 8, 1977	
				14. Sponsoring Agency Code	
15. Supplementary Notes					
16. Abstract <p>About 2:53 a.m. on October 8, 1977, Southern Railway Company train No. 1, The Crescent, entered a crossover from the main track into the Spencer Yard at Spencer, North Carolina, and sideswiped freight cars which were being assembled as train No. 152 on an adjacent yard track. Four locomotive units and five cars of The Crescent and seven cars of train No. 152 were derailed. Twenty-six persons received minor injuries, and damage was estimated to be \$250,000.</p> <p>The National Transportation Safety Board determines that the probable cause of this accident was the failure of the switch circuit controller to cause a red aspect to be displayed at the entrance to the signal block. Contributing to the cause of the accident was the Southern's failure to insure by enforceable, specific rules that conflicting routes were not established for The Crescent and train No. 152.</p> <p>A recommendation was made to the Federal Railroad Administration concerning the signal circuit used at Spencer to achieve a track shunt when a switch is operated to reverse and to the Southern Railway Company relative to specific operating rules and their enforcement.</p>					
17. Key Words Circuit controller, track shunt circuit, side collision, crossover, reverse position, normal position, false clear, rule 93, emergency evacuation, a.c. track circuit, hand switch, automatic signal.				18. Distribution Statement This document is available to the public through the National Technical Information Service, Springfield, Virginia 22151.	
19. Security Classification (of this report) UNCLASSIFIED		20. Security Classification (of this page) UNCLASSIFIED		21. No. of Pages 24	22. Price H02-H07

CONTENTS

	Page
SYNOPSIS	1
INVESTIGATION	1
The Accident	1
Injuries to Persons	4
Damage.	4
Personnel Information	4
Method of Operation	5
Signal Information.	7
Meteorological Information	8
Medical and Pathological Information.	8
Survival Aspects	9
Tests and Research	9
Other Information	11
ANALYSIS	12
CONCLUSIONS	14
Findings	14
Probable Cause	14
RECOMMENDATIONS	15
APPENDIXES	17
Appendix A - Excerpts from Southern Operating Rules	17
Appendix B - Excerpts From Rules, Standards, and Instructions	19
Appendix C - Circuit Controller Information	20

.-

NATIONAL TRANSPORTATION SAFETY BOARD
WASHINGTON, D.C. 20594

RAILROAD ACCIDENT REPORT

Adopted: May 11, 1978

SIDE COLLISION OF
SOUTHERN RAILWAY COMPANY TRAINS
NOS. 1 AND 152
SPENCER, NORTH CAROLINA
OCTOBER 8, 1977

SYNOPSIS

About 2:53 a.m. on October 8, 1977, Southern Railway Company passenger train No. 1, The Crescent, entered a crossover leading from the main track onto a yard track at Spencer, North Carolina, and sideswiped freight cars which were being assembled as Southern train No. 152. Four locomotive units and five cars of The Crescent and seven cars of train No. 152 were derailed. Twenty-six persons received minor injuries, and damage was estimated to be \$250,000.

The National Transportation Safety Board determines that the probable cause of this accident was the failure of the switch circuit controller to cause a red aspect to be displayed at the entrance to the signal block. Contributing to the cause of the accident was the Southern's failure to insure by enforceable, specific rules that conflicting routes were not established for The Crescent and train No. 152.

INVESTIGATION

The Accident

About 11:00 p.m. on October 7, 1977, a Southern yard engine with 49 empty freight cars approached the Spencer Yard on the southbound main track. After a crewmember lined the Old Spencer Depot crossover for movement from the main track to the yard, the train proceeded, without stopping, into the yard. The yardmaster had instructed the crew not to stop to reline the switch ^{1/} for movement on the main track; therefore, the crossover was left unattended.

The yardmaster testified that about 11:00 p.m., he instructed a switch tender to go to the north end of the yard to line the crossover for movement on the main track after the yard engine came into the yard, and to bleed the air off of cars on the Old Southbound Yard track.

^{1/} During the investigation of this accident the Southern's Superintendent of Operating Rules, Eastern Lines, defined a switch as meaning both ends of a crossover. However, precise reference requires that each end of the switch be identified by direction -- in this case, north or south.

The switch tender stated that he did not see the yard train enter the yard after he arrived at the north yard shanty, about 700 feet south of the crossover. He called the yardmaster shortly after 11:00 p.m. and was informed that the yard engine had arrived. The switch tender then bled the air from the cars standing on the Old Southbound Yard track. He did not line the switch of the crossover for movement on the main track, and later he denied that he had been instructed to do so. About 11:50 p.m. the switch tender reported to the yardmaster that he had completed his last assignment. The yardmaster stated that he assumed this included lining the switch at the crossover for the main track; he did not ask specifically about the switch, however.

About 2:00 a.m. on October 8, 1977, the engineer and head brakeman for Southern train No. 152 left the Spencer Yard roundhouse on the locomotive to assemble the train's cars which were standing on two tracks. The locomotive's route was over the south switch of the crossover. The locomotive was stopped, and the brakeman lined the south switch of the crossover for movement on the running track, which paralleled the southbound main track. (See figure 1.) At that time he did not observe the north switch of the crossover, about 400 feet away. After the locomotive was coupled to the cars on one of the tracks, the yardmaster instructed the engineer to pull north on the running track and to wait for The Crescent to pass before moving again. When the locomotive of No. 152 passed the north switch of the crossover, the brakeman saw that the switch was lined so that trains would move from the southbound main track, over the crossover, and into the Spencer Yard. He suggested that the engineer call the yardmaster to determine if he wanted the switch to be lined for the main track, but the engineer replied, "the yardmaster knows about it." Shortly thereafter, about 2:53 a.m., Southern's southbound train No. 1, The Crescent, entered the crossover about 50 mph and collided with several cars of train No. 152 on the running track.

The Crescent had left Greensboro, North Carolina, at 1:45 a.m. on October 8, 1977. The train consisted of 4 locomotive units and 11 passenger cars. The locomotive was equipped with a two-way radio and the conductor was provided with a portable radio. A 500-mile brake test made before departure disclosed no defects.

While en route to Spencer, the engineer frequently communicated by radio with the train dispatcher, Southern's northbound train No. 2, and a freight train. The speed of the train was reduced from 70 mph to 50 mph as it approached Spencer, to comply with a speed restriction, and the engineer and fireman testified that the wayside signals displayed clear indications. They called the signal indications to each other as required by the operating rules. The engineer and the fireman discussed the fact that all of the signals were clear, because usually The Crescent was routed from the southbound track to the northbound track at Spencer for movement into the station at Salisbury, North Carolina. When a train is to follow this route, signal 330.7 should display an "approach"

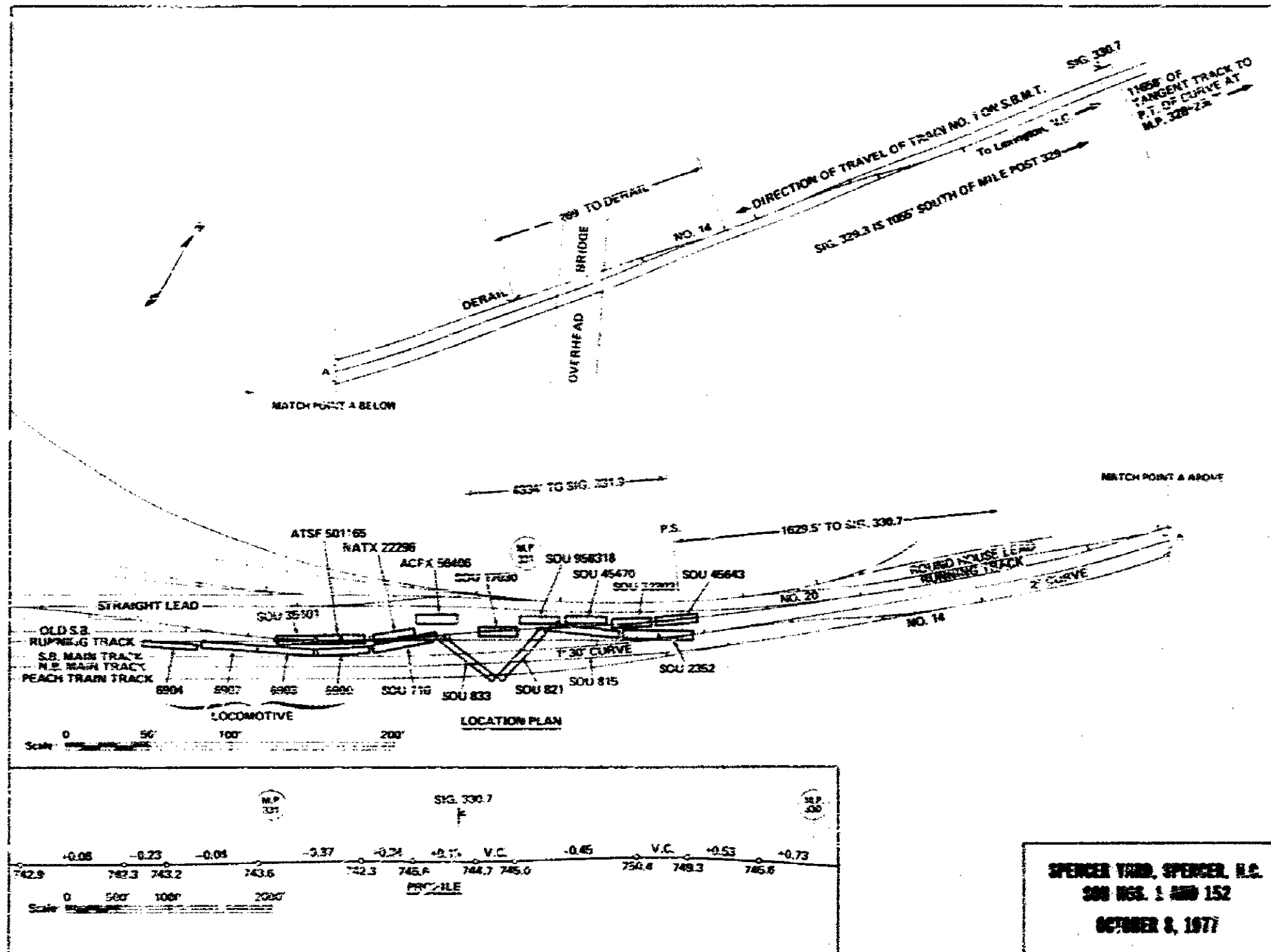

Figure 1. Accident site.

aspect. The engineer usually called the yardmaster on the radio whenever the signal indications approaching Spencer were less favorable than clear. A "clear" aspect on signal 330.7 indicated that the train would continue on the southbound main track.

Shortly after The Crescent passed signal 330.7, it entered the north switch of the crossover and was routed from the main track to the running track in the Spencer Yard where it collided with the freight cars of train No. 152.

A 2° right curve begins immediately south of signal 330.7 and changes to 1°30' with a 1-inch superelevation at the point of the derailment. There is a 50-mph speed limit through the curve. The grade through the same area is 0.37 percent descending southbound. (See figure 1.) The north switch of the Old Spencer Depot crossover is a facing point switch for southbound trains; it is 1,629 ft south of signal 330.7. The crossover is about 380 ft long with No. 14 turnouts. The rail through the Spencer area is 132-lb continuous welded rail.

Injuries to Persons

<u>Injuries</u>	<u>Traincrew</u>	<u>Passengers</u>	<u>Other</u>
Fatal	0	0	0
Nonfatal	0	17	9
None	5	105	

Damage

The four locomotive units of The Crescent were derailed but remained upright and parallel to the main track. The lead unit was damaged extensively along the right side. The first five cars behind the locomotive were derailed; the second and third of these cars jackknifed toward the west. The passenger equipment was damaged slightly.

The second, third, and fourth cars were coaches, and the fifth car was a sleeper-lounge. The seats of the second and third cars remained intact and there was little interior damage. Five seats in the fourth car had rotated one-quarter turn. The right-front corner of the fourth car was crushed inward to the extent that the aisle was impassable. Otherwise, the interiors of the cars sustained little damage.

Four freight cars of train No. 152 derailed but remained upright, and three were turned on their sides. The freight cars were slightly damaged. About 400 ft of track was destroyed.

Personnel Information

The engineer of The Crescent was employed April 30, 1937, and was promoted to engineer on July 3, 1958. He passed a medical examination

in February 1977, and a rules examination on March 7, 1977. He was wearing corrective lenses for far-sightedness, as required, at the time of the accident.

The fireman of The Crescent was employed July 29, 1973, as a trainman. He was promoted to conductor on October 15, 1975, and transferred to engine service as a fireman on October 1, 1977. He passed a medical examination in September 1977, and an operating rules examination in March 1977. He was an engineer trainee and had made three or four round trips over the division on The Crescent.

The engineer of train No. 152 was employed October 20, 1971, as a yardman. He became a road trainman on November 4, 1972, a fireman on May 2, 1974, and he was promoted to engineer on February 5, 1975. He passed an operating rules examination in March 1977.

The brakeman of train No. 152 was employed October 3, 1972. He passed an operating rules examination in March 1977.

The signal maintainer on whose territory the accident occurred was employed on August 30, 1971, as a signalman. He became signal maintainer at Salisbury on October 6, 1973. He passed a rules examination in February or March 1977. He attended a company signal training school for 2 weeks during December 1972. He had worked for 6 years in electronics before coming to work as a signal maintainer for the Southern. He was responsible for 15 miles of automatic block signal (ABS) double-track territory.

Method of Operation

Trains are operated through Spencer on the main tracks by the indications of an ABS system. The east and west tracks are designated northbound and southbound; respectively.

The accident occurred on the main track within yard limits. According to the Southern, rule 93 of its operating rules applies: therefore, the yardmaster can direct operations on the main tracks within the yard limits. (See Appendix A.) The yard limits for Spencer and Salisbury are contiguous for his control purposes. A crewmember must obtain permission from the yardmaster before using a mainline switch.

Southern operating rule 104(c) states, in part: "A switch must not be left open unattended." Rule 1203 states, in part: "Yardmasters must require that main track switches be properly lined and locked when not in use...." Rule 104(e) requires that, "A train or engine must not foul a track until switches and derails connected with the movement are properly lined...."

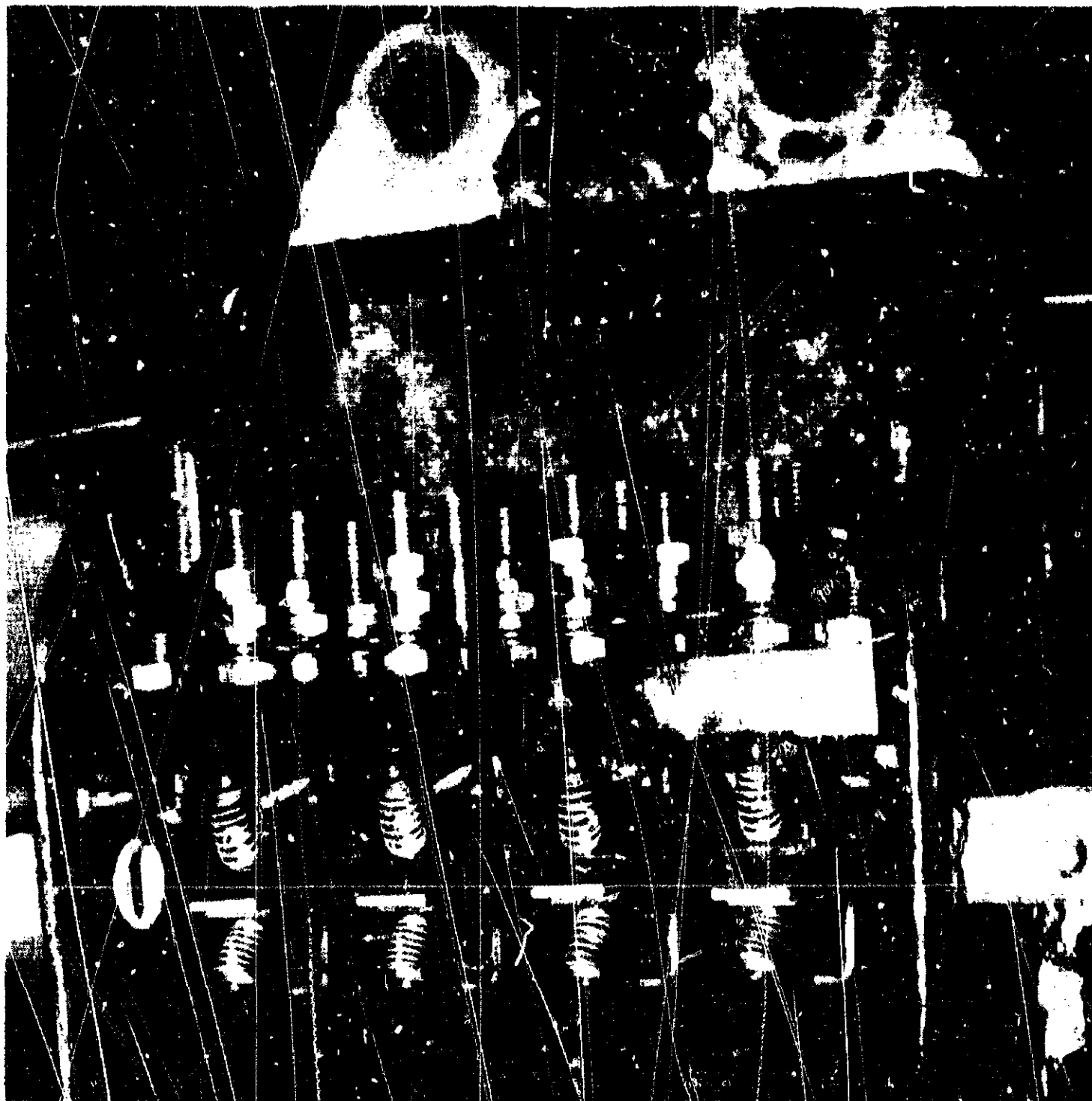

Figure 2. Circuit controller showing contacts and contact jumpers on terminal board.

After the accident, the Southern's Superintendent of Operating Rules, Eastern Lines, stated that he interpreted Rule 104(c) to allow the yardmaster to assume the responsibility for closing switches used by yard crews. He also interpreted rule 104(e) to mean that before a train or engine passes over a crossover both switches must be lined in agreement before a train or engine fouls either end. Yard crews involved stated that they understood these interpretations; however, the practices which were followed, such as not being near a switch when in attendance, the yardmaster assuming the responsibility for a switch, and not lining both ends of a crossover in agreement before using it, were considered by the crewmembers to be approved inasmuch as Southern management did not restrict their use.

The yardmaster was provided with radios, a two-way speaker system, and a telephone for communications. There were no documented procedures to govern the use of the speaker system on the yard. The yardmaster did not remotely operate any switches or have any switch position indicators in the yard office. Switch targets were not used on the main tracks in ABS territory.

Signal Information

Automatic signal 330.7, a number plate signal, governs the main track for southbound trains through the signal block in which the accident occurred. Signal 329.3 is the signal in approach to signal 330.7. When the signal block governed by signal 330.7 is unoccupied, and there are no conflicting routes lined in the block, signal 330.7 should display a green (clear) aspect. If the block is occupied, or if one of the switches of a crossover leading from the main track is in a reverse position, or if a switch is not fully closed for movement on the main track, signal 330.7 indicates red (restricted proceed), which permits a train to proceed at restricted speed. (See Appendix A.) When signal 330.7 displays a red aspect, signal 329.3 should display a yellow (approach) aspect.

A red signal aspect on signal 330.7 can be caused, among other reasons, by a shunt circuit ^{2/} between the two running rails. A shunt circuit can be imposed by the presence of a train or by a switch that either is not fully closed in a normal position, or is in a full reverse position. The shunt removes the track voltage from the track relay; this causes the signal to display a red aspect. Federal regulations (49 CFR 236.6) require that when a facing-point, hand-operated switch equipped with a circuit controller connected to the switch points is operated 1/4 inch or more from its normal position, track or control circuits will be opened or shunted or both. The shunt at Spencer Yard was imposed by the closing of electrical contacts within a circuit controller. (See Appendix C and figure 2.)

^{2/} A low-resistance connection across the source of supply between it and the operating unit. (Association of American Railroads Signal Section Handbook, Part 55.)

The shunt wires were two 5/16-inch, stranded, insulated track wires which had a tapered plug on one end driven into a hole in the web of the rail. Each rail had two wires that were connected to separate contacts in the circuit controller. Each of these contacts in the circuit controller were then connected parallel to another set of contacts to provide redundancy in shunt circuit paths. The movement of either switch of the crossover from 1/4 inch to a full reverse position should have caused signal 330.7 to display a red aspect.

Paragraph 236.5 of the Rules, Standards, and Instructions for signal systems (RS&I) promulgated by the Federal Railroad Administration (FRA) requires that, "All control circuits the functioning of which affects safety on train operation shall be designed on the closed circuit principle, except circuits for roadway equipment of intermittent automatic trainstop system." (See Appendix B.) The application of the circuit controller in the shunt circuit at the Old Spencer Depot crossover did not meet this requirement. The RS&I (Para. 236.103) also requires that circuit controllers be tested and inspected at least once every 3 months. The Southern requires that they be tested and inspected each month and the company provides instructions and procedures for this test. The tests and inspection schedule for the circuit controllers on the crossover had been complied with. The maintainer's report of tests and inspections for August and September of 1977 showed that the circuit controllers for the crossover were "inspected and tested [and] left working as intended." The last adjustment was made September 19, 1977, and the last inspection was made the next day.

The Southern does not specify a measureable value for the pressure exerted by the spring tension of the hinged contact. Signal maintainers estimated the force by feel. ^{3/} A typical inspection of the controller includes checking contact pressure, checking for loose terminal nuts, terminal boards or rollers, and a check for excessive dust. The track circuit voltage is checked to determine if the track is being shunted when the contacts in the circuit controller are closed for the shunt circuit.

Meteorological Information

At the time of the accident, the weather was dark but clear with good visibility. The temperature was 56° F and the humidity was 70 percent.

Medical and Pathological Information

Passenger injuries were described as pain in the extremities, and in the back, neck, hip, face, and shoulders. One person complained of

^{3/} Part 49 of the Association of American Railroads Signal Manual of Recommended Practices specifies that the contact pressure in a closed position shall be not less than 3 lbs 8 oz.

low back pain, numbness of both legs, and abdominal pain. This passenger was seated on the toilet in his bedroom when the accident occurred.

Survival Aspects

The end doors of the derailed second coach could not be opened because of the position of the derailed car. Rescue personnel broke a window in the passenger compartment to remove occupants of that car.

Most of the injured passengers were located in the third car. Five were removed on stretchers through a window. The passengers apparently were injured when they struck seats or were struck by baggage. Only three of the injured were admitted to a hospital.

The conductor reported that luggage and coats from the overhead luggage racks were dislodged and objects were seen hurtling through the fourth car; however, no injuries resulting from the dislodged baggage were reported.

Rescue and emergency forces responded from Salisbury and other nearby communities. The Sheriff's Department from adjoining Davidson County also assisted. All of the injured were removed in less than 1 hour after the accident and all passengers were removed from the site within 90 to 100 minutes.

Tests and Research

Signal approach tests were made between 9:00 p.m. and 11:00 p.m. on October 12, 1977, to determine the visibility of the aspects displayed by signals Nos. 329.3 and 330.7. A similar locomotive was placed approximately where train No. 152's locomotive was at the time of the accident, with its headlight burning. Another locomotive, similar to The Crescent's locomotive, was selected to simulate that train.

The view of signal 329.3 was unimpaired as the test train approached. However, as the test train approached signal 330.7, test personnel noted that the signal's aspect was temporarily lost from view until the locomotive was about 1,000 ft from the signal, because of glare from the headlight of the locomotive simulating that of train No. 152. The engineer and fireman of The Crescent said the headlight did not limit their view of the signal aspect before the accident, however.

The circuit controller, a General Railway Signal (GRS) model 5, was tested in its installed position on October 8, 1976, and on a test bench on October 12, 1977. (See Appendix C.) The postaccident inspection disclosed that the box was undamaged. It was securely and properly mounted and neither the switch points nor the rods attached to the controller were damaged. Before the circuit controller was removed from service, a signal supervisor observed that one contact appeared not to close properly; the supervisor could not identify the contact later, however. (See figure 3.)

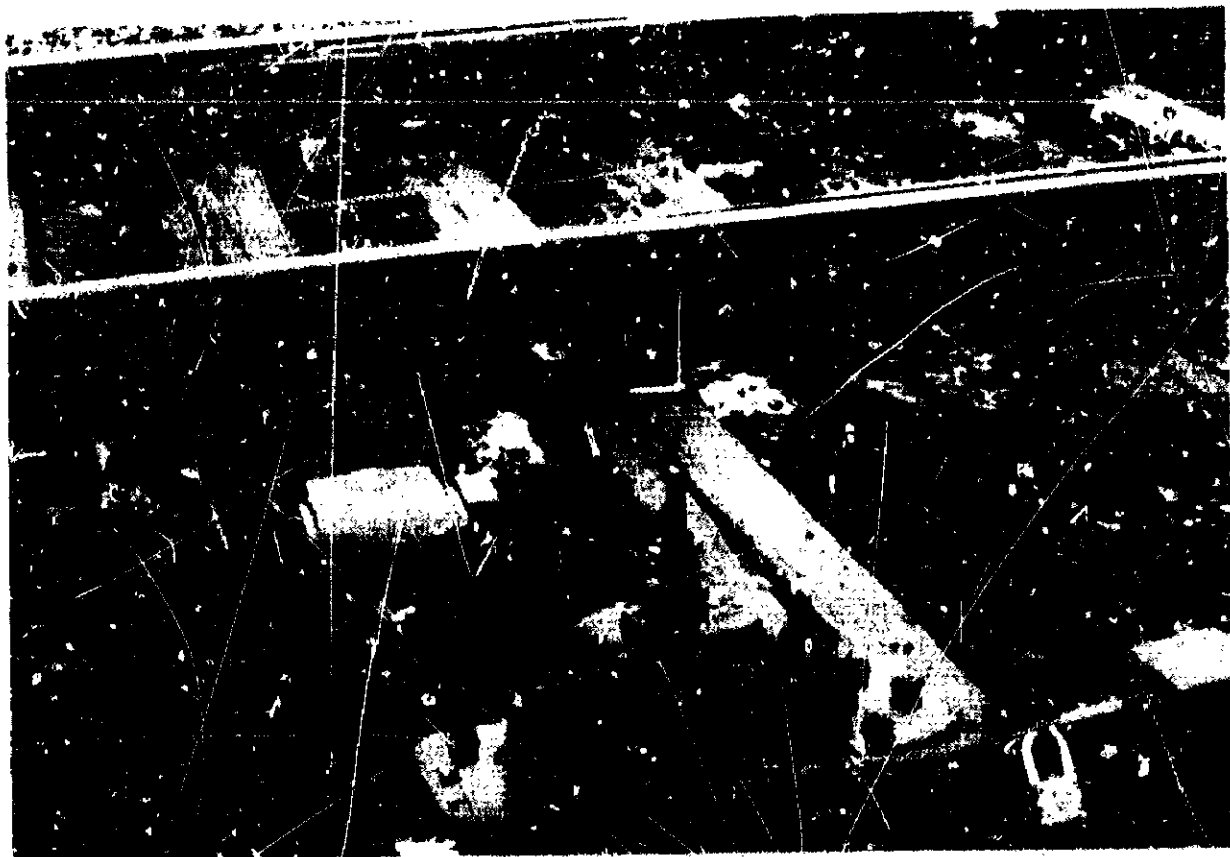

Figure 3. North end of Old Spencer Depot crossover showing circuit controller in its installed position.

A black residue, similar to a grease-dirt mixture, coated the plug of the shunt wire from the No. 4 contact of the circuit controller. Investigators found that the coating was resistant to current flow when it was tested for conductivity with an ohm-meter. However, there were also several bright spots on the plug which indicated good conductivity. The plug hole in the web of the rail also was coated with the black substance. A Southern signalman testified that this hole was cleaned to bright metal with sandpaper before shunt wires were reinstalled soon after the accident. The conductivity from rail to rail through the circuit controller or from the circuit controller through the shunt wires to the rail was not tested.

When the track was restored so the track circuit was operable, the main track switch of the crossover was operated several times to determine its effect on the signals. Each time, zero voltage was indicated on a voltmeter and the proper signal aspect was observed on signals 330.7 and

329.3. These tests were made on October 8, 1977, before any adjustments were made to the circuit controller. On October 9, 1977, a signal maintainer adjusted two contacts in the circuit controller because the track forces had changed the track alignment through the switch. He did not remember which two contacts he adjusted.

On October 12, 1977, the circuit controller unit was removed from service for further testing and inspection. When the circuit controller was operated a number of times, it was found that contacts Nos. 1, 2, and 3 failed to close completely. The phenolic terminal board, which contains part of the contact assemblies, was loose. The controller box was disassembled for a detailed inspection and a flat spot, not considered significant, was found on the No. 1 operating cam. Excessive play also was observed in the No. 4 contact roller.

The signal block governed by signal 330.7 was 6,336 ft long. The a.c. track voltage operates a three-position polar a.c. track relay. Inspections and tests of signal and track relays at signal 330.7 disclosed that they were all operating within specifications, and there was no evidence of conditions that would cause sticking contacts or improper operation. Tests were made at signal 330.7 to determine if foreign current was present at a sufficient level to operate the signal relays or cause them to fail to operate. There was no measureable foreign current detected. Also, insulation resistance tests of the signal instrument case wiring and the case-to-signalhead wiring was made and no faults were detected.

Other Information

A Southern conductor testified that on May 20, 1977, he was on a train that entered the Spencer Yard through the crossover just ahead of The Crescent. His brakeman had lined the south switch for the running track but had not lined the north switch for the main track when the conductor said he heard The Crescent "rev his engines up" and begin to accelerate as if it had received a "clear" aspect at signal 330.7. The conductor immediately went to the north switch and lined it for The Crescent to use the main track. He learned later that The Crescent's engineer said signal 330.7 changed from red to green when the south end of the crossover was lined for the running track. The conductor reported the incident to a trainmaster in a casual manner, but no one investigated the incident to determine what had happened.

During the latter part of May 1977, or the first of June 1977, a freight train entered Spencer Yard through the crossover. A brakeman had lined the south end of the crossover for the running track but before he had lined the north end for the main track, he heard a following train begin to accelerate as though signal 330.7 had changed to a "clear" aspect. He called the engineer of the following train on his radio and

told him that the main track switch was still lined for the yard. The engineer responded that he had a "clear" aspect on signal 330.7, but he slowed the train so that the switch could be properly lined. The traincrew did not properly report the incident to a supervisor. The brakeman testified that he reported the incident to his conductor; however, the conductor testified that he did not recall the report or any action that he might have taken.

Southern signal department employees stated that they did not receive any report of a false "clear" signal in either incident. Federal regulations, section 26, 49 CFR Part 234, paragraph 234.0, require that "all failures of block signal systems...to indicate or function as intended" be reported. (See Appendix B.)

ANALYSIS

Although they were not properly reported as required by Southern's rules and by Federal regulations, the instances in which engineers said that signal 330.7 indicated "clear" when the crossover switch was in a reverse position must be considered valid. The actions of the engineer of The Crescent in reducing speed from 70 mph to 50 mph in compliance with a speed restriction, the discussion of the infrequent display of a "clear" aspect on signal 330.7, and the engineer's general performance leading up to the accident also support the theory that signal 330.7 was displaying a "clear" aspect while the crossover switch was in the reverse position.

The adjustments made to the two contacts in the circuit controller on October 9, 1977, precluded a conclusive test of the controller's reliability. However, the failure of the contact which the signal supervisor observed after the accident, the contacts which failed during the tests on October 12, and the general condition of the controller assembly (loose terminal board and excessive play in the No. 4 contact roller) indicate a lack of reliability. Also, the circuit could have failed to shunt effectively, and thus permitted a "clear" aspect, because of the foreign matter found on the shunt wire plug and in the rail hole. The substance may have produced a high resistance that prevented the track shunt from "shunting" enough voltage from the track relay to allow it to become deenergized and cause a red aspect to be displayed by signal 330.7. A shunt would not have occurred if the contacts had failed to operate properly, or if the shunt wires had broken.

In spite of the fact that the controller operated properly each time the switches were tested on October 8, the cumulative evidence leads the Safety Board to conclude that the controller was defective and could have failed intermittently. Therefore, the Safety Board concludes that signal 330.7 displayed a "clear" aspect while the crossover switch was in the reverse position. Because of the "clear" aspect, The Crescent's engineer acted in accordance with operating rules when he entered the signal block.

The application of the circuit controller in the shunt circuit at the Old Spencer Depot crossover did not meet the requirements of the FRA's RS&I. The installation of a series or break-type circuit -- a variation of the shunt circuit -- would have provided a higher degree of protection. Because the track shunt circuit protecting the crossover in the signal block governed by signal 330.7 was not designed to "fail safe" ^{4/}, the Southern should have insured the protection of trains using the crossover through its operating rules and responsible personnel. Although Southern's rule 104(c) clearly stated, "a switch must not be left open unattended," Southern's interpretation of the rule allowed the yardmaster to assume responsibility for leaving the switch open even though he did not attend the switch. Even though Southern's rule 1203 stated, "yardmasters must require that main track switches be properly lined and locked when not in use," the yardmaster authorized a yard crew to leave the main track switch of the crossover open and unattended, and he then failed to insure that it was closed.

Southern's rule 104(e) did not specify that both switches of a crossover used during a train movement must be lined in agreement before the route is fouled. If this had been required, the engine crew of train No. 152 would have lined the main track switch of the crossover before fouling the running track switch of the crossover, and the collision would have been avoided. Having signal operations that are not configured to "fail safe" is unreliable enough without the added deficiency of operating rules that do not specify clearly what is required of employees and supervisors in circumstances which rules 104(c), 1203, and 104(e) are intended to control.

In spite of the signal component failure, this accident would have been avoided if the yardmaster had exercised his supervisory responsibility and fulfilled his assumed responsibility for returning the switches to normal. Whether or not the yardmaster instructed the switch tender to return the switches to normal, the yardmaster was responsible for insuring that the switches were lined properly before The Crescent arrived, because he had relieved the yard crew of that responsibility when they used the route about 11:00 p.m. on October 7.

The engineer and brakeman of train No. 152 failed to exercise good judgment when they operated their locomotive on the running track near the crossover while they knew that the main track switch was in the reverse position. When they occupied the switch area with cars of train No. 152, they assumed the responsibility of leaving the main track switch in the reverse position.

^{4/} A term used to designate a railway signaling design principle, the objective of which is to eliminate the hazardous effects of a failure of a component system. Addendum A, Association of American Railroads Signal Manual Part 55.

CONCLUSIONS

Findings

1. The adjustments made to the two contacts in the circuit controller on October 9, 1977, made it impossible to test conclusively the controller's reliability.
2. The circuit controller unit did not perform as intended at the time of the accident; it may have been operating improperly as long as 4 months before this accident.
3. Signal 330.7 was displaying a "clear" aspect as The Crescent approached and the train's engineer operated consistent with operating rules.
4. The shunt circuit configuration used on the Old Spencer Depot crossover is not based on a "fail-safe" design. The series break-type available as an alternate circuit is superior and gives more reliable protection.
5. The track shunt protection intended to be provided by the Old Spencer Depot crossover when either or both ends of the crossover were positioned other than "full normal" was not provided because of a discrepancy in the shunt circuitry.
6. The yardmaster was authorized by the Southern operating rules to control train movements on main tracks within the Spencer Yard limits.
7. The yardmaster's authority to assume charge of a switch in absentia was not clearly defined by the Southern's rules, even though he was charged with the responsibility for all switches within the yard.
8. The enginecrew of train No. 152 did not discharge their responsibility to line the north switch of the Old Spencer Depot crossover.

Probable Cause

The National Transportation Safety Board determines that the probable cause of this accident was the failure of the switch circuit controller to cause a red aspect to be displayed at the entrance to the signal block. Contributing to the cause of the accident was the Southern's failure to insure by enforceable, specific rules that conflicting routes were not established for the Crescent and train No. 152.

RECOMMENDATIONS

As a result of its investigation of this accident, the National Transportation Safety Board recommended:

-- to the Federal Railroad Administration:

"Require that the track shunt circuit imposed by contact closure in a circuit controller be phased out as soon as practicable and a series break-type circuit, which will satisfy the requirements of the FRA's Rules, Standards, and Instructions, be used in place thereof. (Class II, Priority Action) (R-78-23)"

-- to the Southern Railway Company:

"Revise its operating rules to insure that they state as specifically as possible the action that is intended, and to enforce those rules pertaining to the operation of switches and the reporting of malfunctions of the signal system. (Class II, Priority Action) (R-78-24)"

BY THE NATIONAL TRANSPORTATION SAFETY BOARD

/s/ JAMES L. KING
Chairman

/s/ FRANCIS H. McADAMS
Member

/s/ PHILIP A. HOGUE
Member

/s/ ELWOOD T. DRIVER
Member

May 11, 1978

APPENDIX A

Excerpts From Southern Operating Rules

Rule 104(c): A switch must not be left open unattended. When another train or engine is to use a switch, it may be left open when left in charge of a member of the crew of such train or engine.

* * *

Rule 104(e): A train or engine must not foul a track until switches and derails connected with the movement are properly lined or, in the case of spring switches, the normal route is seen to be clear. When waiting to cross from one track to another, and during the approach or passage of a train or movement on tracks involved all switches connected with the movement must be secured in normal position. Switches must not be restored to normal position until a movement is completed or clear of the main track involved. Where trains or engines are required to be reported clear of main track, such report must not be made until switch has been secured in its normal position.

* * *

Rule 1203: Yardmasters must require that main track switches be properly lined and locked when not in use; that bad order cars be placed for repairs or transfer; that prescribed records be maintained and designated reports made.

* * *

Rule 93: Within yard limits the main track may be used, clearing by at least five minutes the time an approaching first class train is due to leave the nearest station where time is shown. A train or engine that fails to clear main track by the required time must be protected as prescribed by Rule 99.

At locations where special instructions require all trains to move at yard speed, the main track may be used without protecting against first class trains, but inferior trains and engines must not delay first class trains.

All trains and engines within yard limits except first class trains must move at yard speed, not exceeding 20 MPH, unless the main track is known to be clear by automatic block signal indication. Protection against other than first class trains is not required within yard limits.

A train or engine must not move against the current of traffic within yard limits until provision has been made for the protection of such movement by train order, yardmaster, or other designated person, and then must move at yard speed, not exceeding 20 MPH.

Preceding page blank

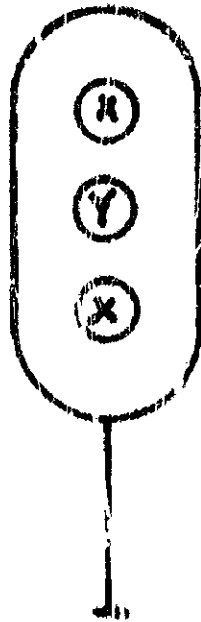

RULE 307 - Name; Approach.

Indication: Proceed, preparing to stop at next signal.
Train exceeding Medium Speed must at once reduce to that speed.

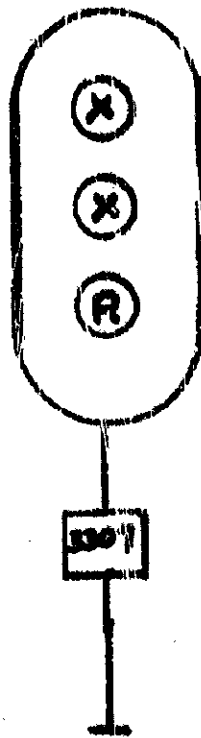

Number Plate

RULE 309 - Name: Restricted Proceed

Indication: Proceed at Restricted Speed.

Y = Yellow
R = Red
X = Dark

APPENDIX B

Excerpts From FRA Rules, Standards, and Instructions

Part 234 - Signal Failure Reports

§ 234.0 Monthly and telegraphic reports required.

(a) All carriers subject to section 26 of Title 49 of the United States Code shall report monthly, within 30 days after the end of each month, all failures of block signal systems, interlocking, automatic trainstop, train control and cab signal devices, and other similar appliances, methods and systems to indicate or function as intended.

* * *

§ 236.5 Design of control circuits on closed circuit principle.

All control circuit the functioning of which affects safety on train operation shall be designed on the closed circuit principle, except circuits for roadway equipment of intermittent automatic trainstop system.

§ 236.6 Hand-operated switch equipped with switch circuit controller.

Hand-operated switch equipped with switch circuit controller connected to the point, or with facing-point lock and circuit controller, shall be so maintained that when point is open one-fourth inch or more on facing-point switch and three-eighths inch or more on trailing-point switch, track or control circuits will be opened or shunted or both, and if equipped with facing-point lock with circuit controller, switch cannot be locked. On such hand-operated switch, switch circuit controllers, facing-point locks, switch-and-lock movements, and their connections shall be securely fastened in place, and contacts maintained with an opening of not less than one-sixteenth inch when open.

* * *

§ 236.103 Switch circuit controller

Switch circuit controller shall be inspected and tested at least once every three months.

APPENDIX C

PLATE K0119

GENERAL RAILWAY SIGNAL COMPANY

AUGUST 1928

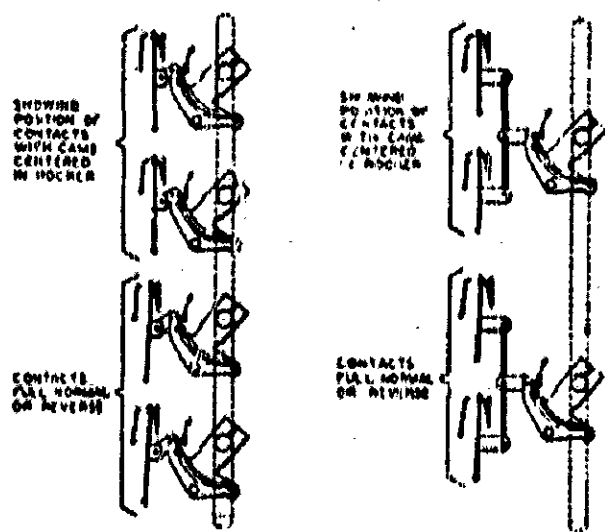
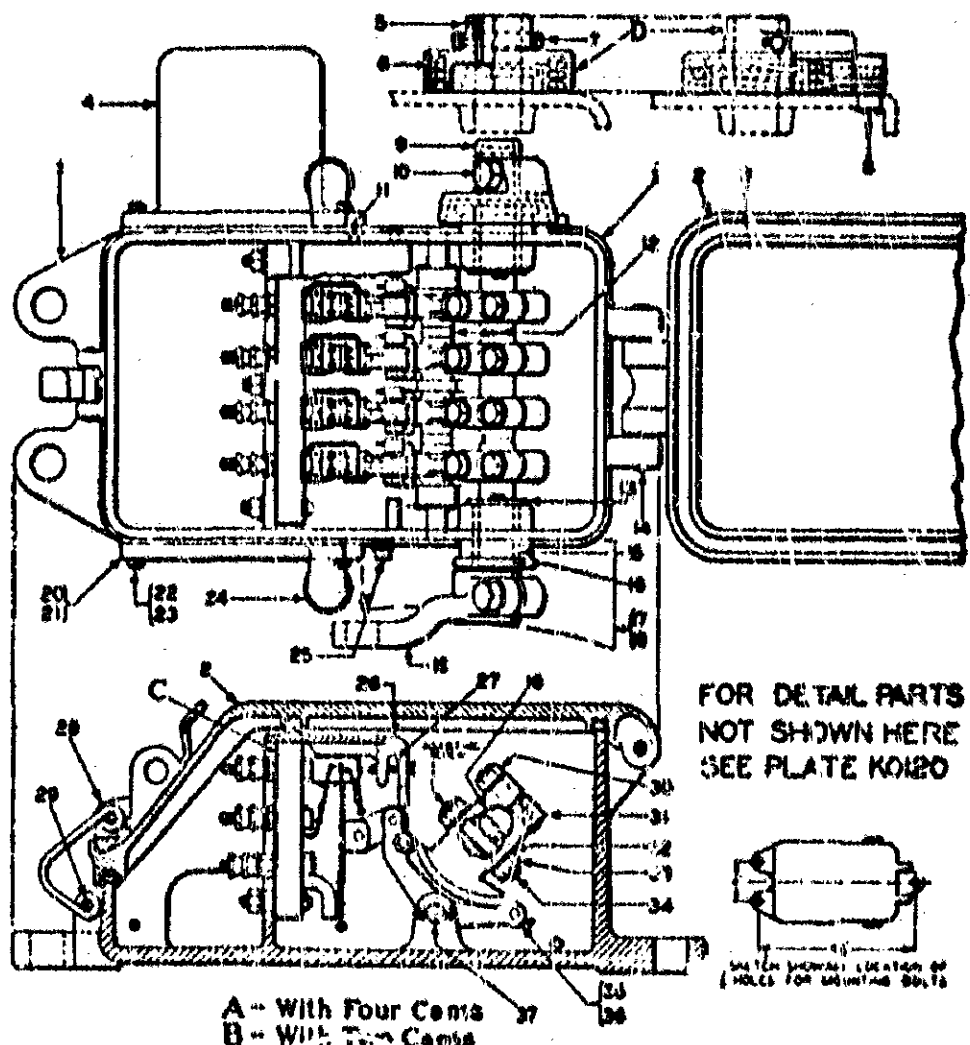

ARRANGEMENT OF CAMS AND CONTACTS IN FIG. A.

ARRANGEMENT OF CAMS AND CONTACTS IN FIG. B.

Model 5 Switch Circuit Controllers Two Position, Round Hobbed Shaft

Rail Connector replaced after track forces accidently broke connection on Saturday, Oct. 8, 1977

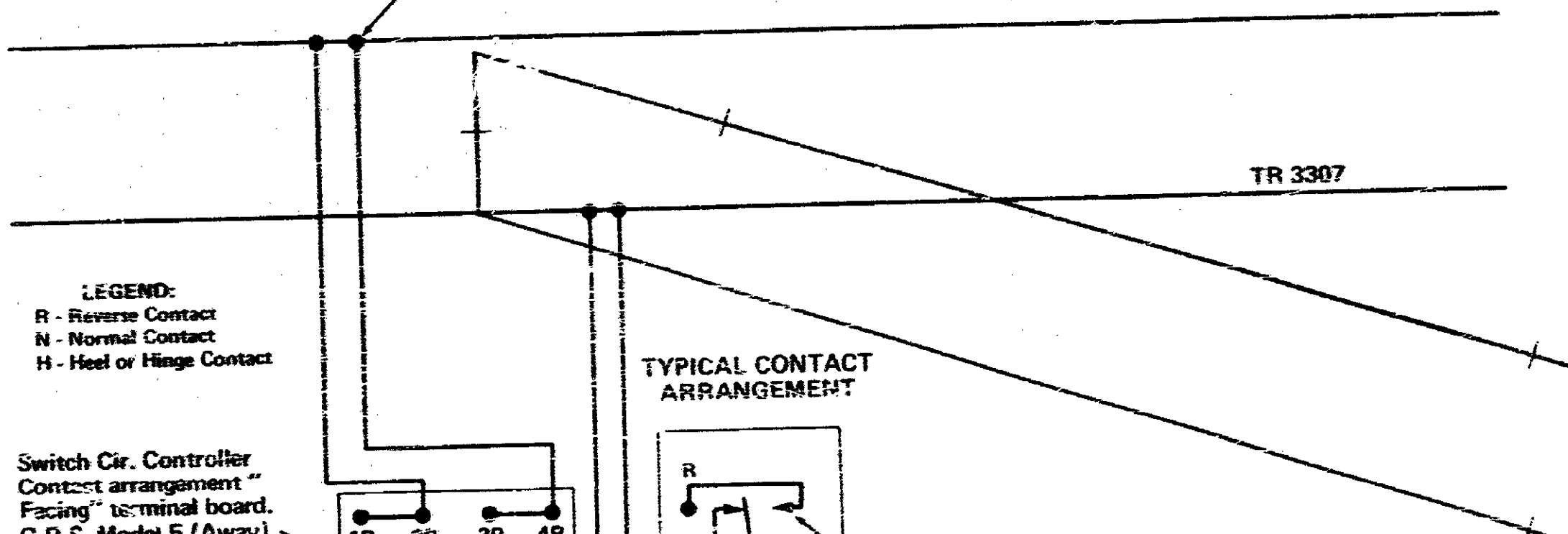

LEGEND:
 R - Reverse Contact
 N - Normal Contact
 H - Heel or Hinge Contact

Switch Cir. Controller Contact arrangement "Facing" terminal board. G.R.S. Model 5 (Away)
 When switch is 1/4 inch off normal to full reverse, 1H closes to 1R, 2H closes to 2R, 3H closes to 3R and 4H closes to 4R. Note jumpers from 1R to 2R, 3R to 4R, 1H to 2H and 3H to 4H.

TYPICAL CONTACT ARRANGEMENT

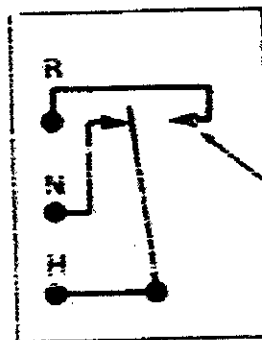

Shunt Contact Closed 1/4 inch off Normal to Full reverse position.

NOTE: The wire arrangement shown above is "EXACT" as existed at time of investigation, Oct. 12, 1977. Southern Railway, North end of "Old Spencer Depot" Crossover, 1629 feet south of ABS Signal 330.7. Switch Circuit Controller Contacts 1, 2 and 3 failed to shunt TR 3307 with switch in 1/4 inch off normal to full reverse switch position. Eastern Division - Eastern Lines.

APPENDIX C (cont'd)